

SHM: A practical approach

- Set up several SHM examples around the room.
- Students into groups of three (as per cooperative learning, assign tasks; e.g. an organiser, time keeper, recorder etc), provide newsprint and pens.
- Students to record observations on paper and state what is similar about each situation.

Example Situations:

1. Swinging pendulum bob.
2. Vibrating ruler clamped to a bench.
3. Water in a U-tube or a weighted test-tube in a measuring cylinder.
4. A vertical spring-mass system.
5. A horizontal spring-mass system (on an air-track)
6. Needle in a sewing machine.
7. Middle of a plucked guitar string.
8. Ball-bearing on a curved track.
9. Video of a person bouncing on a trampoline (bouncing while touching the mat)
10. A torsional oscillation.

- Groups to be assigned two or three situation each and report back to the whole class orally and pictorially.
- Establish by class discussion the following:
 - repetitive motion
 - straight line / or nearly so
 - changing velocity (max in the middle, zero at ends)
 - changing acceleration (zero in middle, max at ends)
 - changing force (same as acceleration)
 - force acting towards the centre

Practical Activity : Developing the Reference Circle Approach

- Revise ideas on **Year 12 Circular Motion**, add to this definitions of angular velocity (ω), and tangential velocity (v).

Equipment needed:

- find at least 5m square of space on flat ground preferably tarseal
- two lengths of rope 2m and 5m (climbing rope diameter is best),
- some chalk sticks
- a stop watch
- meter ruler
- video camera for a long term record (optional)

Setting:

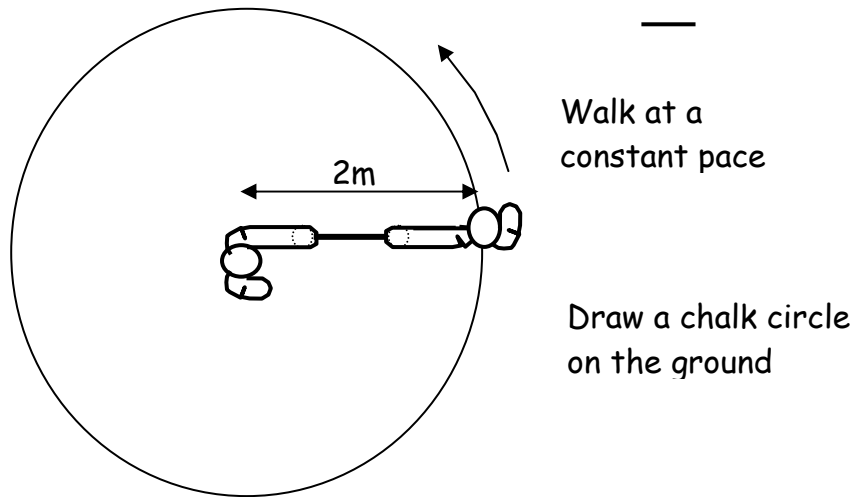

- Alongside the marked out circle, about 1m out draw a straight line the length of one diameter (4m)

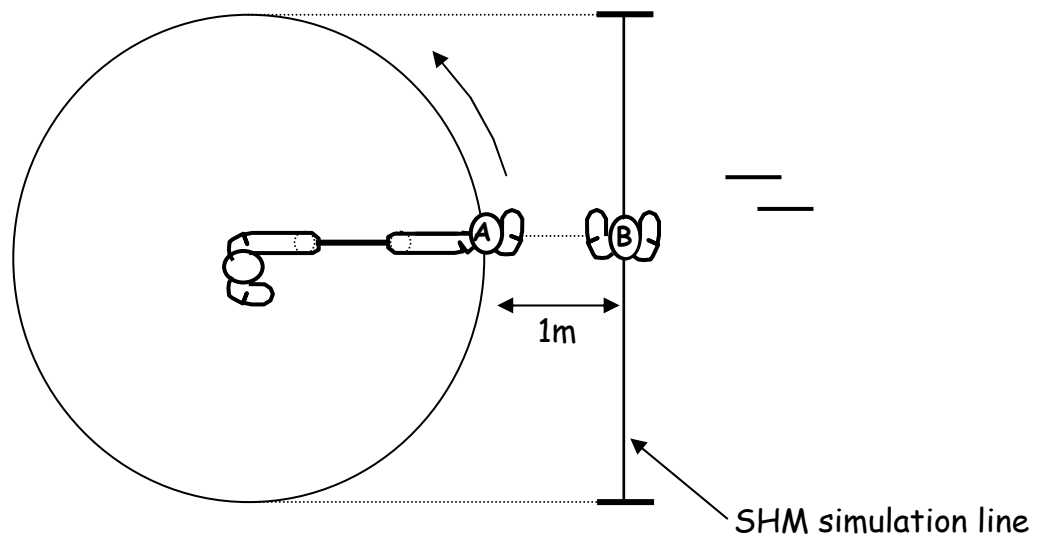

- Get **student B** to walk the SHM line trying to keep in line with **student A** at all times, this activity is designed to give **student B** the feel of SHM (you should relate this activity with 'shuttle runs' in PE).
- Review the earlier class discussion on 'what' characterises SHM...highlight the similarities.
- Now speed up **student A** encouraging **student B** in the process, make sure as many of the students as possible do this activity.

Relationship between Circular and Simple Harmonic Motion

- Using two students either side of the circle, span the 5m rope so that all three students hold the rope, as per the diagram (**student A** needs to hold the rope loosely or use a specially designed eyelet).

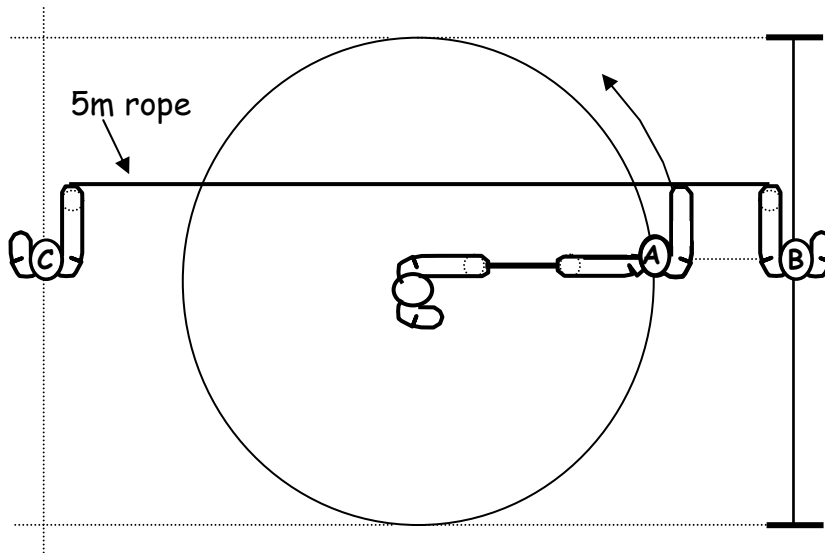

- This activity must occur at a slow speed and **students A, B and C** must stay in line (this will work with patience)
- Now mark eight equally spaced points on the circumference of the circle i.e. at 0, 45, 90, 135, 180, 225, 270, 315 and 360°.
- As the 5m rope intersects these points mark them on the SHM simulation line.

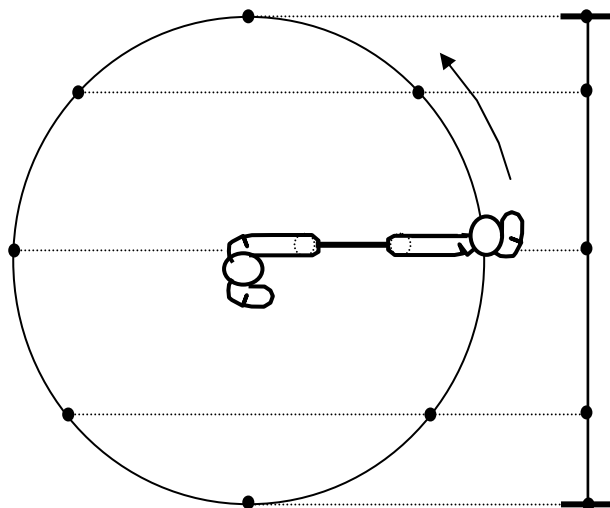

- Discuss the time taken to travel between adjacent points, if there is some doubt verify using the stopwatch.
- As an extension you could mark out a Position vs Time graph on the ground beside the SHM simulation line. A fourth student could be used to keep pace with students A, B and C to mark out the successive displacements, use a 'stop frame' approach here to slow down the action.

